

Section 5

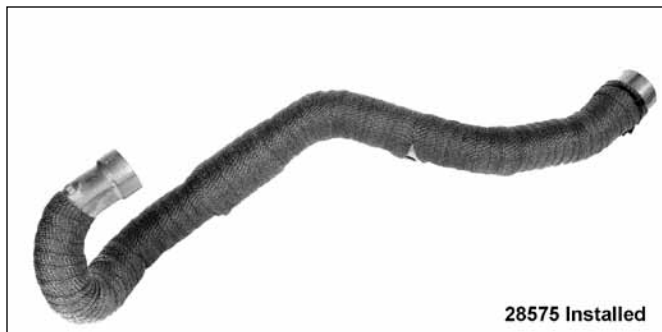
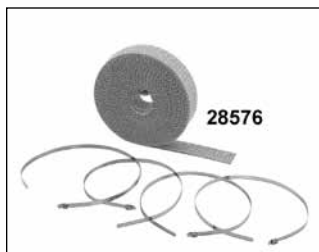

High Temperature Exhaust Wrap Kits

Applying this premium wrap will increase power and reduce radiated exhaust heat. This wrap can handle 1200°F continuous; 2000°F intermittent. Kits are available in black or tan and include 4 extra-long stainless steel tie wraps for that finishing touch.

PCP	Width	Length	Colour
28575	2"	25'	Black
28576	2"	25'	Tan
28577	1"	50'	Black
28578	1"	50'	Tan
28579	14" Replacement stainless steel ties (4 pack)		

Baffles-Brackets-Clamps2,13,15,21

Drag Pipes 12

Hardware 34

Mufflers4-6,8,10,16-22,24-28

Heat Shields2,11,23,30-33

Cycle Shack

Fat Boy7

FLT, FLHS17,23-26

FXDB, FXDC 8

FXR6

FXST,FLST2-5

Sportster, Evo 1986-ON10-11

Paughco4,26-29

Samson9,18,22

FXST-FLST



95233 PHD-140SS, 1-3/4 Slash muffler pipes



95258 PHD-114TA, 1-3/4" Tapered Muffler Pipes

Cycle Shack Muffler Pipes- PHD-114 Series

Cycle Shack's PHD-114 Series 1-3/4" and 2" pipes fit FXST, FLST 1984-on and 1985-86 4-speed FXE. Features include true one-piece construction, accepts the original factory heat shield and has 1-3/4" head pipes and 2-1/2" diameter mufflers. Uses stock flange rings, gaskets, and hardware and will mount to the factory bracket. 1984-94 fits bracket 65459-84A and 1995 versions fit bracket 65459-95.

2000-06	1984-99	Muffler Style
95231	95258	Tapered
-	95264	As above 2"
-	95260	Turn-out
95233	-	Super slash
95234	-	1-3/4" Drag pipes
95235	-	2" Drag pipes



Muffler/Drag Pipe Heat Shields

Designed to fit with either Drag or Muffler type pipes. Covers do not have cut out for cross-over tube. Sold in sets.

- 94020** Smooth BT Evo
- 94021** Perforated BT Evo
- 94024** Ribbed BT Evo
- 94025** Smooth XL 1986-03



Chrome Stock Heat Shields 1986-99

- | PCP | Application |
|--------------|---------------------------|
| 45565 | Front FXST-FXR (65732-86) |
| 45566 | Rear FXST-FXR (65702-86) |



Chrome Heat Shields

Stock replacement shields include worm clamps.

- | PCP | Application |
|--------------|-----------------------------|
| 45564 | 1986-99 FXR-FXST (65410-83) |

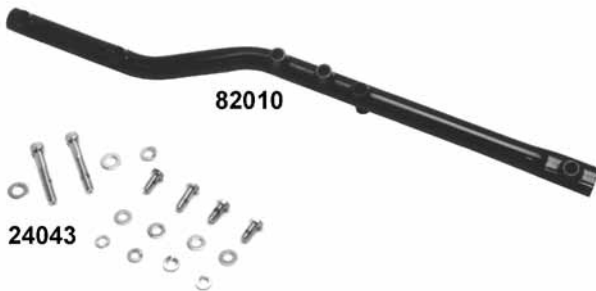

FXST, FLST Exhaust Support

Support mounts stock or custom drag pipes to frame. Stock on FXST but can be used on Fat Boy to mount lower drag pipes. PCP 82010 can be used on 1995-on models to mount early style Porkster or Cycle Shack drag pipes.

PCP	Application
82010	FX, FLST 1984-94, black (65459-84A)
82011	As above, chrome
82012	FX, FLST 1995-99, chrome (65459-95)
82013	FXSTF-N 1995-99, chrome (65515-95)
82088	FLSTF, FXST 2000-06, black (65435-00)
24043	Chrome bolt kit



Stainless Steel Exhaust Taper Valves

- 27501** Evo (pair)



Drag Pipes-Cycle Shack

These 38" long straight-through drag pipes fit the 1984-on FXST-FLST Softail®. Available in traditional 1-3/4" diameter or beefier 2" O.D. tubing. Front pipe mounts to factory support tube or use our BK-8 mount kit #27008 (not included) and rear pipe mounts to chrome fender strut. To be used with factory flange rings and gaskets.

95234 1-3/4" FXST Drag pipes 1984-06

95235 2" as above for 1984-06



6444 PHD-114GF, 1 3/4" Mini-Tail Muffler Pipes 1984-99

Shotgun Muffler Pipes-Cycle Shack

This is the look the 1984-99 Harley-Davidson FXST-FLST Softail was made for. This traditional rigid look is available with 1-3/4" O.D. head pipes with Mini-Tails mufflers. All feature our exclusive 16-gauge tubing, true one-piece construction, and show-chrome. Fits 1984-99 FXST-FLST Softails. (will not fit 1985-86 FX 4 speed models). Use our 1164 heat shield to keep boots and pants from melting all over the beautiful show-chrome. Front pipe mounts to factory support tube or to our BK-8 Mounting kit (not included, see below).

6444 Mini-Tail Mufflers 1984-99



Down Draft 2-1/4" Pipe Set

Fits 1986-06 FXST and 1999-06 TC-88. Looks great with #21813 turbo fan velocity stack, sold separately.

95311



Stainless Steel Taper Valve Exhaust Kit

This valve fits into the header at the flange area to compensate for exhaust velocity when large diameter pipes are installed. Fits Evo and XL models 1986-on with large O.D. aftermarket pipes. Kit includes 2 valves with gaskets.

27502 Kit

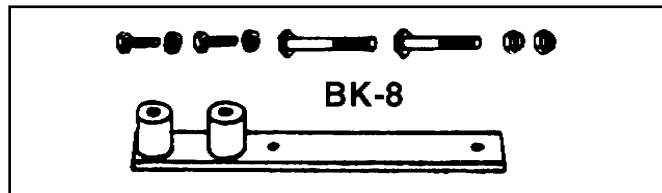

Mounting Bracket

This BK-8 mount bracket kit can be used in place of the factory muffler support tube (OEM#65459-84A or #65459-95) for a cleaner installation with our part numbers PHD-114GT/PHD-114GTA, PHD-114GS/PHD-114GSA, PHD-114G/PHD-114GA, PHD-114GF/PHD-114GFA, PHD-214GT/PHD-214GTA, PHD101G/PHD101GA, PHD-201/PHD201GA

27008 (Cycle Shack BK-8)



Maxx-Shot FXST Exhaust Set

Features 1-3/4" headers with full cover 2-1/4" form fit cover set. Brackets included for 1986-06 FXST models EV and TC-88.

95984

FXST



Chrome Up Sweep Header Sets by Paughco

Pipes include brackets and will accept straight fishtail extensions or mufflers which must be purchased and mounted separately.

PCP	Application
95988	1984-94 FXST
95989	1995-06 FXST



Evo Exhaust Flanges - Chromed

Fits 1983-on 1340 BT and replaces 65328-83.

27202	Kit as shown
753	Kit (2 clamps, 2 retainers)
11105	Snap rings (65325-83) (10 Pack)
25172	Stainless woven gaskets (pr)
10807	Exhaust stud (5 pack)



Pirate 2" Curved Pipe Set FXST 1986-06

95948



Cycle Shack Replacement Mufflers 1995-99

Light weight, 2 1/2" O.D. slip-fit replacement mufflers for 1995-99 FXST, FLST, FLSTF, and FLSTN "Fatboy" models; feature an all-steel core that will not burn out. 1995-99 models bolt to OEM bracket #65459-95.

Sold in pairs

PCP	Style	Description
94750	Tapered	FXST-FLST 1995-99
94754	Tapered	FLSTF/N "Fatboy" 1995-99
94755	Baloney	FLSTF/N "Fatboy" 1995-99
94756	Turn-outs	FLSTF/N "Fatboy" 1995-99

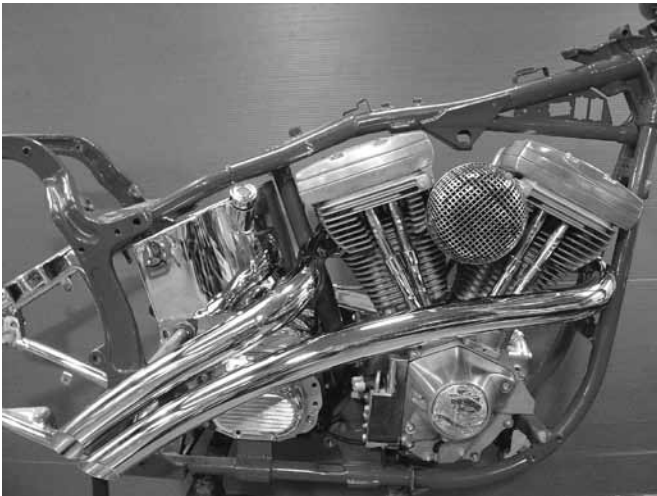

Chrome Radii Pipe Set

Features full curve with 2" OD for 1984-on FXST models with Rigid or Softail frame. Bracket included.

PCP	Years
95955	1984-06

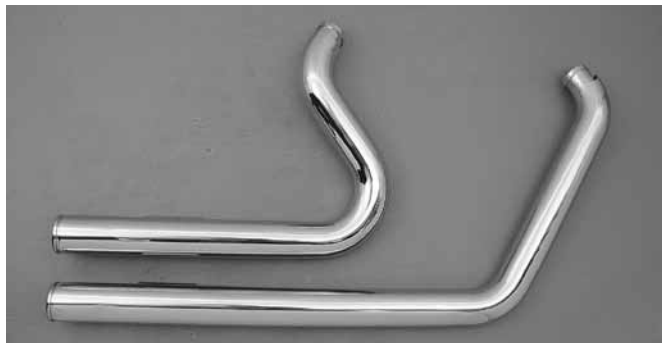

FXST Short Stuff Pipe Set

Features 1-3/4" headers with full coverage 2-1/4" heat shield set.

95959



MCM FXST Drag Pipe Sets

Pipes are 1-3/4" slash cut style 38" length and mount by stock brackets. Heat shields are included with PCP #95957 only.

95957 1984-99, with formed heat shields

95964 2000-06

95965 1984-99

95966 2" pipes 1984-99



95981

Radii Monster Drag Pipes

Feature 2-1/4" O.D. and include mount brackets for 1986-06 FXST models. Order baffles separately. Black end caps fit straight cut pipes by drilling 1/4" mount hole

PCP Style

95981 Down slash

95985* Straight cut (short)

95968 Down slash (short)

95969 Straight cut

82016 Mount bracket

21681 Black 2 1/4" end caps

* No mounting hardware



95968



95985



95969



2-1/4" Torque Tube Set

Will quiet loudness.

73564



Exhaust Gasket for Harley Evolutions

A woven wire mesh crush gasket for use with all Evolution motors when installing OEM or aftermarket exhaust systems. (OEM 65324-83A).

25172 Pair

FXR-FXRT-FXLR Models



95714

Cycle Shack Mufflers for FXR-FXRS-FXLR

Replacement mufflers for the 1982-86 FXR-FXRS-FXLR and the 1987-94 FXR-FXRS-FXLR models. Choice of classic tapered, bold "SS", or stylish turn-out designs to give your FXR a new look. These low restriction show-chrome beauties also offer improved performance. Includes hidden channel mounts and T-bolts for mounting to factory support tube. Uses stock clamps. **Sold as a set of 2.**

1982-86 FXR-FXRS

- 3534 Turn-Out Mufflers
- 3536 Tapered Mufflers
- 3538 Baloney-Slice "SS" Mufflers

1987-94 FXR-FXRS

- 95715 Turn-Out Mufflers



6432 PHD-123T, 1-3/4" Tapered Muffler Pipes

1-3/4" Muffler Pipes-Cycle Shack

Cycle Shack's PHD-123 series 1-3/4" muffler pipes fit the 1984-94 Evolution rubber mount FXR, FXRS, FXRT, & FXLR models (including the 1986-on Low Rider and Super Glide). Feature an exclusive 16-gauge tubing, true one-piece construction, and show-chrome. 2-1/2" diameter with all steel mufflers are designed to use stock flange rings, gaskets, clamps, and hardware. Mounts to factory bracket with concealed mounts for great ground clearance.

Cycle Shack Staggered Duals

for 1984-94 and 1999-00 FXR Series

- 6432 1-3/4" Tapered style (shown)
- 95228 2" Tapered Muffler pipes (PHD-223T)



Preston's 2" Side Sweeper Exhaust Pipes

Fits 2000-on FXST models without floorboards. Pipes have oxygen sensor ports with plugs which can be removed for 2007-on models to install sensors.

95962



6436

Drag Pipes-Cycle Shack

Your choice of 1-3/4" O.D. or 2" O.D. 40" long straight-through pipes for drag racing. Fits 1984-94 Evolution engine rubber mount FXR, FXRS, FXRT, and FXLR models (including the 1986-on Low Rider® and Super Glide®). Includes channel mounts and hardware for mounting to factory brackets. Designed to be used with factory clamps, flange rings, and gaskets.

- 6436 1-3/4" Drag Pipes
- 6437 2" Drag Pipes

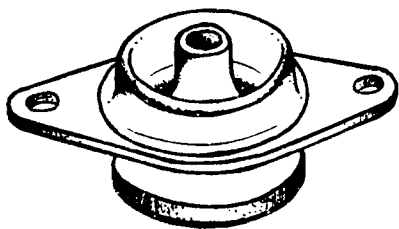

FXR Exhaust Bracket Mounting Block

Fits all FXR 1982-86 models. Replaces 65780-82. Each.

27242

FLSTF "Fat Boy"



Cycle Shack 1-3/4" Muffler Pipes

These tapered, "SS", and Mini-Tails muffler pipes are designed as a direct bolt-on replacement for the factory's original exhaust system on the new FLSTF "Fat Boy" and Nostalgia models 1991-06. They accept the original factory heat shields and feature 1-3/4" head pipes, an exclusive 1-piece construction and show-chrome. Offers improved looks and performance. These pipes eliminate the cross-over tube used on OEM factory pipes and bolt directly to the factory muffler support bars (except 1995-later models) by reusing stock flange rings and mounting hardware. Order bracket BK-11 (Preston 27009) to mount 1995-later models.

95105 Baloney-Slice "SS" Muffler Pipes (PHD-128SS)

95104 Tapered Muffler Pipes (shown) (PHD-128T)

95106 Mini-Tails Muffler Pipes (PHD-128F)

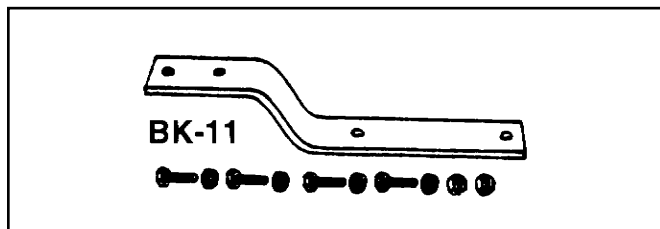

Mounting Bracket Kit

The BK-11 bracket kit is used for mounting the front pipe to 1995-later FLSTF/FLSTN models.

27009 BK-11



Heat Shield

This beautiful chrome 7" long leg protector will keep your passenger's boots and pants from melting on your exhaust pipes. Fits 1-1/2" to 2" O.D. pipes.

1164



FXST Turnout Pipes 1984-94

6442 PHD114TO



Slash Cut 12" Muffler Pipe Baffles

3315 All steel construction

FXD-FXDC-FXDWG



1-3/4" Drag Pipes-Cycle Shack

These 40"-long, 1-3/4" straight-through drag pipes are designed to fit the 1991-on FXDB "Sturgis" and FXDC "Dyna-Glide" models. These pipes accept factory heat shields and re-use the original factory flange rings, gaskets, and clamps. Use bracket BK-9 (PC#27006) to mount 1991-on models.

95195 1-3/4" Drag pipes (PHD-149)



Cycle Shack "Slip Fit" Mufflers

Replacement mufflers for the 1991-on* FXDB "Sturgis" and FXDC "Dyna-Glide" models. Your choice of classic tapered, bold "SS", or stylish turn-out styles to give your bike a new look and improved performance with these low restriction show-chrome beauties. Includes hidden channel mounts and T-bolts for mounting to factory support tube. Uses stock clamps. **Sold as a set of 2.**

95710 Baloney Slice mufflers (MS-129)

95711 Tapered mufflers (MT-129)

*For 1991-94 models you must use 1995-on OEM bracket or our #27006



Mounting Bracket

This bracket is the equivalent of OEM# 65674-95 and is available in black. Replaces 65674-90 & 65674-90A when installing Cycle Shack pipes on 1991-on Dyna models

27006 (BK-9)

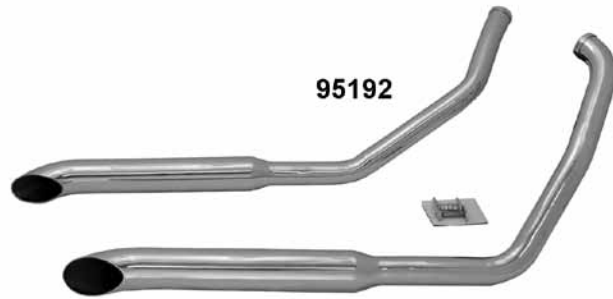

1-3/4" Muffler Pipes-Cycle Shack

These muffler pipes fit the 1991-on FXD, FXDB FXDC, FXDWG "Sturgis" and "Dyna-Glide" models. 1991-94 models require the use of bracket BK-9 (PC27006 replacing OEM 65674-95). They feature 1-3/4" or 2" head pipes; tapered, "SS", turn-out, or Mini-Tails™ styling; our exclusive 16-gauge tubing, one-piece construction; and show-chrome finish. These pipes accept the OEM factory heat shields and re-use the original factory flange rings, gaskets, and clamps.

95192 Turnout (PHD-129TO)

95193 Mini-Tails (PHD-129F)



Preston's Sweeper Exhaust

Fits 1991-on FXD models including 2006-on models with oxygen sensors. Bracket included. Order baffle separately.

95961





95945



95946



95947

Samson Big Guns II Pipes FXST, FLST 1986-06

Features 1-3/4" head pipes with 2-3/4" full coverage heat shields. Includes mounting bracket and hardware. Performance baffle ring is not included.

PCP	Type
95945	Long Shots
95946	Long Slashers
95947	Long Cannons



95975

Dyna 1991-04 (except 2003-04 FXDWG)

PCP	Mfg#	Style
95975	D-206	Classic



95992



95990

Samson "Caliber" Performance Header Sets

Each set features a 4 stepped header pipe and correct pipe diameter to produce the very best power curves and all out performance. Every system has been extensively tested to increase torque and horsepower. Chrome and engraved end caps add the final touch to the "caliber" header that has good looks, rideable power and unequalled sound.

PCP Application

95992 1986-06 FXST



95944

Samson Big Guns II Pipes Dyna 1991-05

Features 1-3/4" head pipes with 2-3/4" full coverage heat shields. Include mounting bracket and hardware. Performance baffle ring is not included.

PCP	Type
95944	Long Cannons

Sportster 1986-03



Cycle Shack XL Replacement Mufflers

Replacement mufflers for the 1980-03 Sportster models supplied with slip-fit staggered duals from the factory. Three styles of these low-restriction, show-chrome beauties to give your Sportster a new look and improved performance. Rear muffler mounts to factory support tube. Order brake pedal stop #2067. Uses stock clamps. Sold as a set of 2.

- 3526** Turn-Out Mufflers
- 3528** Tapered Mufflers
- 3530** Baloney-Slice "SS" Mufflers



1-3/4" Muffler Pipes-Cycle Shack

Cycle Shack's PHD-116A series muffler pipes for 1986-03 883cc, 1100cc, and 1200cc Evolution Sportsters. Your choice of 4 muffler styles, each featuring 1-3/4" head pipes, 2-1/2" mufflers, show chrome, all steel baffles, and an exclusive 16 gauge one-piece construction. Brake pedal stop is incorporated into the front pipe mount.

Uses stock flange rings, gaskets, and hardware and mounts to the factory bracket.

- 6218** Turn-out style
- 6219** Tapered style
- 6220** Slash-cut style
- 6221** Mini-tail style

2" Muffler Pipes

Same great styling and fit as our PHD-116T 1-3/4" pipes (above), but made with beefier 2" O.D. tubing. Fits 1986-03 883cc, 1100cc, and 1200cc Sportsters.

95224



Preston's Sportster Slip-On Mufflers

Mufflers include removable baffle set. One bolt for quick removal.

- 94772** 1980-03
- 94773** 2004-on

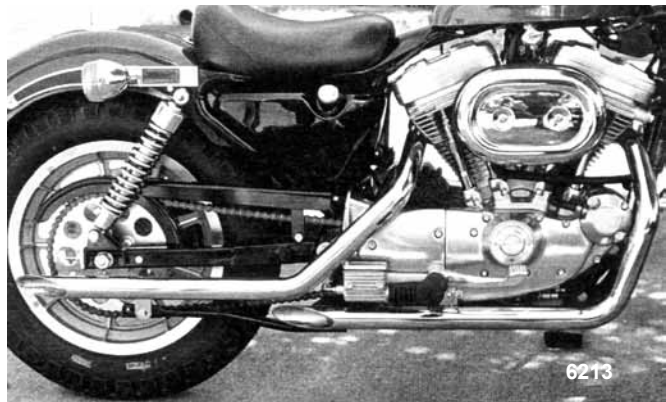

Drag Pipes-Cycle Shack-Sportster 1986-03

Cycle Shack's 1-3/4" drag pipes for 1986-03 883cc, 1100cc, and 1200cc Evolution engine Sportsters feature a true 40" length with show-chrome, hidden channel mounts, and slash-cut ends. Brake pedal stop incorporated into front pipe mount. Bolts to stock mount bracket and uses stock flange rings, gaskets, and hardware.

- 6213** 1-3/4" Drag Pipes (PHD-102A)



95266



95269

Cycle Shack XL Pipe Sets 2004-06

Fits all 883 and 1200 models. Available in muffler or drag pipe style. 1-3/4" Header set accepts factory heatshields. 2" Headers are supplied with heatshield. Both 1-3/4" and 2" type mount to factory support bracket. Muffler pipe sets feature one piece construction and high flow rate baffles for outstanding performance.

1-3/4" Muffler Pipe Set

PCP	Style
95265	Taper (PHD-130T)
95266	SS (PHD-130SS)

Drag Pipe Set

95267	1-3/4" Slash cut end (PHD-131)
95268	2" Slash cut end (PHD-231)
95269	1-3/4" Straight cut end (PHD-131-S)



94027

Preston XL 1986-03 Chrome Covers

For Cycle Shack drag or muffler style pipes

94027 Set



95996

XL Radii Curved Exhaust Headers

2" Diameter pipes for XL models 1986-03.

PCP	Application
95996	1986-03
95998	2004-on bracket

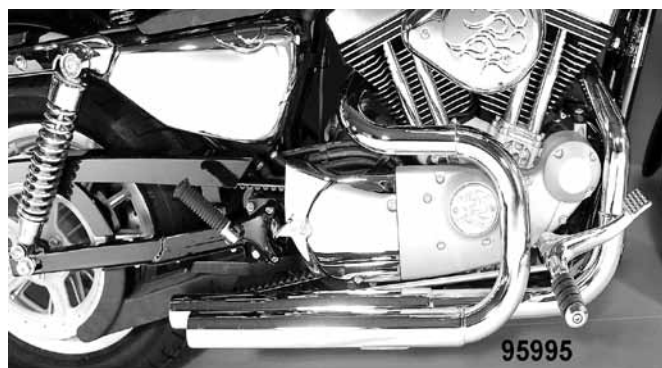

95995

Wyatt XL Side by Side Pipes 2004-on

Fits XL and XLC models with forward controls. Pipes are 1-3/4" at head and 2-1/4" at end and includes baffle set and bracket.

PCP	Type	Years
95995	Straight	2004-06
95999	Slash	2004-06
95971	Slash	2007-on



95999

Drag Pipes

All Cycle Shack Drag Pipes have slotted mounts on rear of pipe. Must use mount brackets on page 5-18. (Not supplied with Cycle Shack Drag Pipes)

Cycle Shack 1-3/4"	Fits	Engine Type	Length Inches
6213	1986-03 EV XL Drags	Evolution	35
6436	1984-* FXR's ONLY	Evolution	38
95234	1984-86 FX, 4-speed FXST 1984-06 FXST, FLST	Evolution	38
95195	1991-FXDB Sturgis	Evolution	36

Cycle Shack 2"

6437
95235



Muffer/Drag Pipe Heat Shields

Designed to fit with either Drag or Muffer type pipes. Covers do not have cut out for cross-over tube. Sold in sets.

- 94020 Smooth BT Evo
- 94021 Perforated BT Evo
- 94024 Ribbed BT Evo
- 94025 Smooth XL 1986-03



Billet End Tips

Fits 1-3/4" straight cut drags.

- | PCP | Finish |
|-------|--------|
| 27137 | Chrome |
| 27138 | Black |

Preston Cycle's Own 1-3/4" FXST Shot Guns

These pipes require "P" clamps (included) for mounting.

Chrome Drag Pipes

PCP	Model	Mounting	Length
95310	1984-99	Stock Tab	40"



Evo Stainless Exhaust Taper Valve

27501 Pair



Kreem Blue Shield

Blue Shield is an internal exhaust pipe sealant that is designed to prevent 'pipe blueing' on properly tuned motors. Since blueing is caused by excessive heat, it may still occur if an engine is not in proper tune or if the carburetor is jetted too lean. Slight blueing may occur on pipes with extremely sharp bends coming from heads. Install on new, clean pipes only.

78008 Each

Mounting Hardware

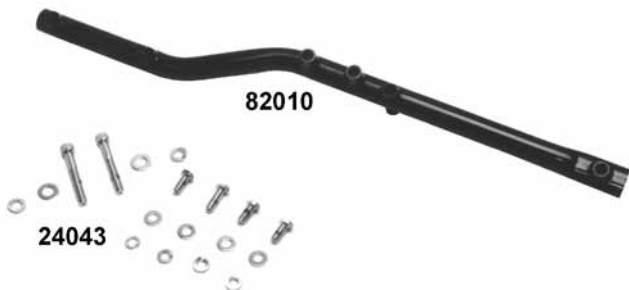

FXST, FLST Exhaust Support

Support mounts stock or custom drag pipes to frame. Stock on FXST but can be used on Fat Boy to mount lower drag pipes. PCP #82010 can be used on 1995-on models to mount early style Porkster or Cycle Shack drag pipes.

PCP Application

- 82010** FXST, FLST 1984-94, black (65459-84A)
- 82011** As above, chrome
- 82012** FXST, FLST 1995-99, chrome (65459-95)
- 82013** FXSTF-N 1995-on, chrome (65515-95)
- 24043** Chrome bolt kit



1999-05 Dyna Chrome Exhaust Support

Replaces 65548-99
27364



XL Chrome Exhaust Bracket 1986-2003

27350 65127-98 (stock)

Exhaust Cross over Bracket 1995-06

27468

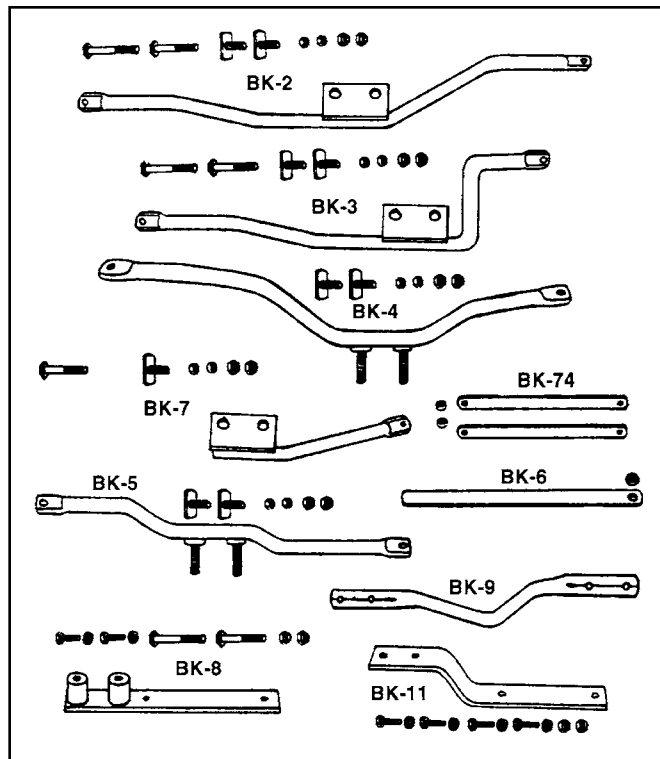

Cycle Shack Mounting Brackets

Supports are available to fit Cycle Shack's muffler and drag pipes. A universal strap bracket is also available to fit most other pipes. Black finish.

PCP Application

- 6650** FXE PHD-115/PHD-215 series muffler and PHD-108 and PHD-208 drag pipes (BK-2)
- 6651** FLH electric start only PHD-118 series (BK-3)
- 6652** XL PHD-112 and PHD-117 series mufflers and PHD-110 and PHD-210 drag pipes (BK-4)
- 6653** Late FLH's with kick and electric start PHD-103 and PHD-120 drag pipes (BK-5)
- 27007** 12" Strap bracket for rear pipe on PHD-121 series muffler and PHD-111 and PHD-113 series Shotgun pipes (BK-6)
- 6654** Early FLH PHD-125 series pipes (BK-7)
- 27008** For use with front pipes from these FXST Shotgun pipes and headers: PHD-114GT, PHD-114GF, PHD-214GT, PHD-201G, PHD-101G and PHD-222 (BK-8)
- 27006** Dyna 1991-on PHD-129 and PHD-149 pipes (BK-9)
- 27009** FLST 1995-04 PHD-128 and PHD-147 (BK-11)
- 732** Pair of 12" long universal strap brackets to fit other pipes for the H-D 74" engine produced with mounting studs. Not for use with adjustable channel mount. (BK-74)



T-Bolt Set

For use with muffler pipes that have channel type mounting. Includes nut.

- 797** 5-16 x 18 bolt set (pair)
- 807** FXR T-bolt set (4 pack)

Baffles & Clamps



Pipe Baffles (Pair)

Fits inside straight pipes, sold in pairs. Note: Baffle size denotes size of pipe into which it fits.

PCP	Size	Length
27360	1-3/4"	8"
27361	2"	8"
27537	2-1/4"	6"



16203

Frame Mounting Clamp

1" Frame clamp for mounting exhaust pipes or foot pegs. Sold in pairs with hardware. Chrome plated.

16203



3078

Chrome Plated Muffler Hanger Clamps

Feature 4-1/2" long strap to mount muffler body to frame. Sold in pairs unless noted.

3075	1-7/8"
3076	2-1/2"
3077	2-3/4"
3066	2-7/8"
3078	3"
3080	3-1/2"
3081	3-7/8"

Short Strap as OEM Bracket

2549	2-7/8" Chrome (each)
3079	3-1/4" Chrome (pair)
3095	3-1/4" Stainless Steel (each)
94201	3-1/4" Chrome (each)



Chrome Smooth Clamps

Use these clamps to connect 1-7/8" O.D. mufflers to 1-3/4" head pipes. The edges are radiused and blend into pipes. Pinch clamp design with allen bolt for tight fit. Pairs.

16337



629

628

3768

Chrome Plated Pipe and Muffler Clamps

Sold each except where noted.

PCP	Size	PCP	Size
774	1-1/4"	629	1-7/8" (pair)
775	1-3/8"	3768	2"
627	1-1/2"		
776	1-5/8"		
628	1-3/4"		



Chrome 1-7/8" ID Muffler End Clamps

Smooth clamps are extra thick for clamping mufflers to 1-3/4" O.D. exhaust pipes. Sold in pairs.

16336

Baffles & Brackets



Mini Pipe Baffles 4"

Short length, full performance, all steel baffles, sold each.

3317	1-3/4"
831	2"



Cycle Shack "SS" Muffler Pipe Baffles

Fits all "SS" style muffler pipes with 2-3/8" I.D.

3315 Sold Each

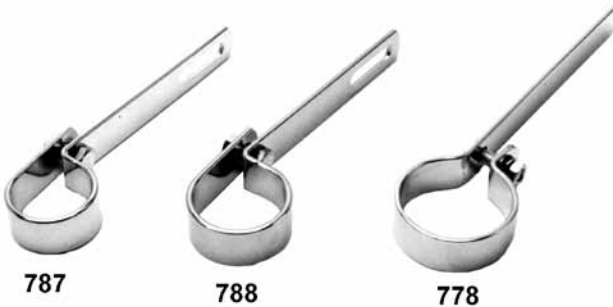

Chrome "P" Clamps

Clamps are made of cold rolled steel and are 1/8" thick and 7/8" wide. The adjustable flat bar of the clamps measures approximately 6-1/2". Sold each.

PCP	Size I.D.
787	1-1/2"
788	1-3/4"
778	2"
59369	2-1/4" (pair)



12" Drag Pipe Baffles

These replacement drag pipe baffles are extra long, sold each.

3556	1-3/4"
3557	2"

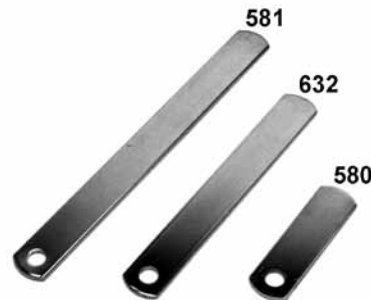

Chrome Universal Flat Straps

PCP	Size
580	3" (each)
632	6" (each)
581	8" (pair)

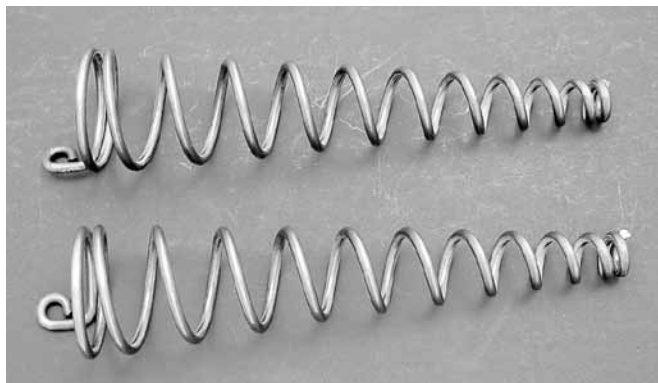

Power Spiral Baffles

Feature the latest designs in exhaust baffles. The minimum restrictive properties of the inverted cone allow for more power and yet still reduce decibel number to acceptable level.

8"	12"	Size of Pipes
73634	73678	1-3/4"
73635	73679	2"
73636	73680	2-1/4"



Chrome Centre Hangar Clamps for Mufflers

Clamps fit muffler OD sizes as noted. Sold in pairs.

Mounting tabs must be drilled.

PCP	OD Size
94202	3"
94203	3 1/4"
94204	3 1/2"

Mufflers



Cycle Shack Replacement Mufflers 1995-99

Light weight, 2 1/2" O.D. slip-fit replacement mufflers for 1995-99 FXST, FLST, FLSTF, and FLSTN "Fatboy" models; feature an all-steel core that will not burn out. 1995-99 models bolt to OEM bracket #65459-95.

Sold in pairs

PCP	Style	Description
94750	Tapered	FXST-FLST 1995-99
94754	Tapered	FLSTF/N "Fatboy" 1995-99
94755	Baloney	FLSTF/N "Fatboy" 1995-99
94756	Turn-outs	FLSTF/N "Fatboy" 1995-99

Cycle Shack Mufflers for FXE and FXST-FLST

Replacement mufflers for the 1980-85 FX-FXE-FXS-FXEF-FXB-FXWG and 1984-94 FXST-FLST Softail® models and the new FLSTF Fat Boy® with staggered dual muffler pipes. Features include lighter weight, 2-1/2" O.D. muffler with an all-steel core that will not burn out. Mount tabs bolt directly to the factory pipe bracket. Uses stock clamps.

Sold as a set of 2.

3520	Turn-Out Mufflers (MHD-134TO)	1984-94
3522	Tapered Mufflers (MHD-134T)	1984-94
3524	Baloney-Slice "SS" Mufflers (MHD-134SA)	1984-94



Replacement Slip On Mufflers

Low restriction mufflers are available in Tapered, 'SS' or Turn-out styles and feature easy installation to factory support and head pipes. Pairs. 2000-06 FXST shown.

FXR, FXRS, FXLR 1982-86

3536	Tapered
3538	SS
3534	Turnout

FXDB, FXDC 1991-05

95711	Tapered
95710	SS

FLSTF, N 1995-99

94754	Tapered
94755	SS
94756	Turnout

FXST, FLST FLSTF

1984-94

FX, FXE, FXS, FXWG

1980-85

3522	Tapered
3524	SS
3520	Turnout

FXST, FLST 1995-99

94750	Tapered
-------	---------

FXR, FXRS, FXLR, FXRT 1987-94

95715	Turnout
-------	---------

ALL XL 1980-03

3528	Tapered
3530	SS
3526	Turnout

FLSTF, FXSTD 2000-06

94766	Tapered
94767	SS

FXST, FLST 2000-06

94763	Tapered
94764	SS
94765	Turnout

FLT-FLHR 1985-later

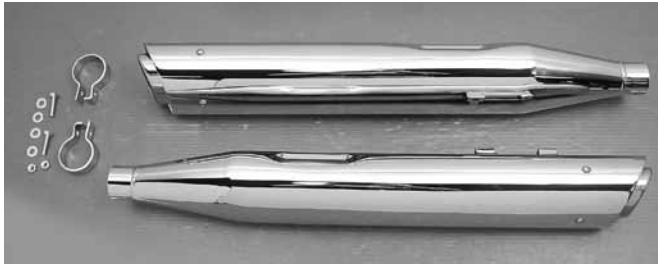

Vance & Hines FLT Oval Slip On Mufflers

Chrome mufflers fit 1995-on and feature full length oval body, full length removable baffle, low restriction design and hidden mounting. Pair.

95729



95102 PHD-126SS, Slash Muffler Pipes

1-3/4" Muffler Pipes-Cycle Shack 1985-94

These staggered duals for 1985-94 FLT-FLHS-FLHTC, and FLHR models with rubber mount Evolution® engines are available in 2 muffler styles, "SS", and turn-down. Each features Cycle Shack's all-steel baffle that will not burn out and get louder. Rear pipe mounts to original factory hanger located under luggage. Frame mounting hardware for front pipe is included.

95102 Baloney-Slice "SS" muffler pipes (PHD-126SS)

95103 Turn-Down muffler pipes (PHD-126TD)

Note*** These pipes do not fit models with oil tank under the transmission.



Rinehart Chrome True Dual Exhaust System

For 1995-06 FLT. Features two oxygen sensor ports in the head pipes, multi-bend radius three stop head pipes that are 1-3/4" at the head to 1-7/8" midway and then a 2" finish, torque chamber baffles, 2-1/4" heat shields that flow into rhw 3-1/2" mufflers and black anodized end caps.

95967



FLT Muffler Gasket 1985-on

25423 65721-92



Wide Oval Mufflers FLT 1995-on

Oval shape mufflers measure 2.5" by 5" Baffles are included. End clamps must be purchased separately.

95758

Samson

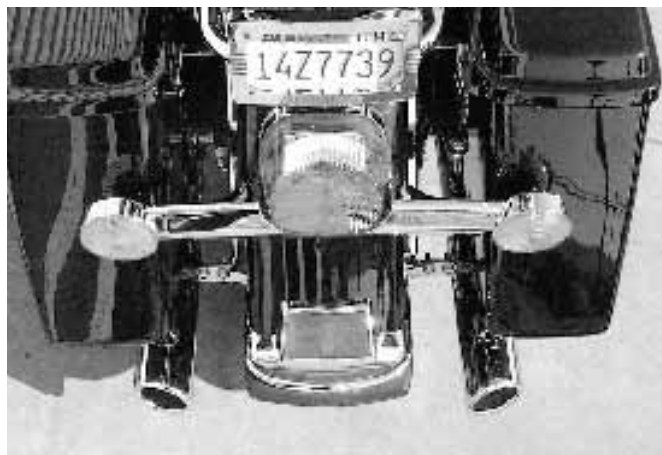

95741 Slash



95737 Oval



95743 Miter



95739 Slant



95745 Straight

Samson "Rolled Thunder" Mufflers

Fits FLT (Touring) models 1985-on. All styles measure 28" long with a 3" diameter and a non removable baffle. Sold in pairs.

PCP	Years	Style
95737	1995-on	Oval (M-136)
95739	1995-on	Slant cut (M-138)
95741	1995-on	Slash cut (M-140)
95745	1995-on	Straight cut (M-144)
95747	1995-on	Oval miter cut (M-147)
95748	1995-on	Oval slant cut (M-148)

Fishtails & Tips



Fishtail Tips

Chrome exhaust tips slip over the outlet of the muffler or straight pipe. Available in 1-3/4" inlet diameter, these classic fishtail tips measure 7" long and 5-5/8" high. (Sold each).

3774 Fishtail 1-3/4" dia. x 7" Length - Fits 1-3/4" Pipe



Fishtail Mufflers - Chrome

2-3/4" diameter with inlet to fit 1-3/4" O.D. pipes. Steel baffle core. Clamps sold separately.

- 6351** 30" long (each)
- 6352** 36" long (each)
- 95751** 31" 1985-94 FLT (pair)
- 3077** Body clamps (pair)
- 629** End clamps (pair)
- 16261** FLT End clamps



Unbaffled Fishtail Straight Pipes

- 94005** 30" FLT 1985-94 w. welded brackets (pair)
- 94006** 30" FLT 1995-on (pair)



Classic Fishtail Muffler

Show-chrome muffler with an antique style tip. This clean, bracketless muffler allows left or right side mounting and has a 1-3/4" inlet. 34" long with 2-1/2" body O.D.

6507



Chrome Tapered 27" Fishtail Muffler

Features 1-3/4" inlet. Uses 2-1/2" body clamps, sold separately, for mounting.

95752 Pair



Chrome 30" Straight Pipe Extension

Has 1-7/8" I.D. to fit over 1-3/4" pipes. Allows extension to slide over to desired length. Pair.

94007

Mufflers



94768

Chrome Universal Turnout Mufflers

Mufflers have a 1-3/4" I.D. inlet and feature a channel type mount track on the rear of the pipe.

PCP	Length	Diameter
94770	20"	2-1/2" (each)
94768	20"	2-1/2" (pair)



1-3/4" Slip-on Muffler

Chrome muffler features megaphone styling with universal mount bracket included.

94769 Pair



94772



94773



Slash Down Muffler

Features removable baffles which can be modified for alternate tuning characteristics. Mufflers bolt to original bracket on 1995-on FLT touring models. 32"L with 3.5" O.D.

PCP	Fits
95771	1995-08
95772	2009-on

XL Slip-On Muffler Sets with Removable Baffle

RMB Style mufflers include removable baffle set. One bolt for quick removal. OAL 18", ID 1-3/4", OD 2-1/2".

94772	1980-03
94773	2004-on
16283	RMB style clamps for above



94775



94776



2:1 Collector Muffler

Muffler has a 1-3/4" inlet, 3" body diameter and is 29" long. Fits to most parallel exit pipes. Turnout end may be rotated to desirable position.

94771

Scalloped Fishtails

Chrome mufflers have a 1-3/4" inlet and offered with 2 body sizes. Includes end clamp. (sold each)

PCP	Length	Muffler O.D.
94775	30"	2-7/8"
94776	22"	2-1/2"

Clamps



Chrome Billet Scalloped Pipe Ends

For 2-1/4" straight pipes. Sold in pairs.
59251



XL 2" Slip-On Drag Pipe Extensions 2004-on

Features removable baffles and cross tube nipples to connect to OEM bracket. RMB style.
94774

Chrome Frame Clamp

Fits frame for exhaust bracket mounting. Each.

PCP	Size
73569	1"
73570	1-1/8"



Exhaust Port Stud and Nut Kit

72188 For Evo and Twin Cam



FLT Muffer Clamps

Choose body or inlet clamps for 1980-up when installing custom mufflers, sold in pairs.

PCP	Item	Finish	Year
16233	Inlet Clamp	Stainless	1985-94 (65722-85)
3487	Wide type	Chrome	1985-94
16229	3" I.D. Body clamp	Chrome	1985-on
23018	Rubber mount	Black	1985-on (65724-85)

Offset Bracket

For exhaust systems.
730

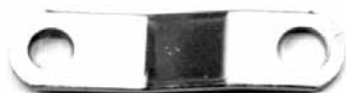

Shown Assembled

Chrome Clamps for Late 1985-94

Chrome steel muffler clamp is an updated version replacing 65722-85. Fits all late 1985-94 FLT/C, FLHT/C.

16261 Each

Mufflers



FLT 2 3/8" Dumper Straight Pipe Sets 1985-on

Fits FLT models and includes baffles. End clamps are sold separately.

PCP	Description
95728	Pipe set 1985-94
95727	Pipe set 1995-on
27365	Baffle set 1985-on
16261	End clamp 1985-94
628	End clamp 1995-on

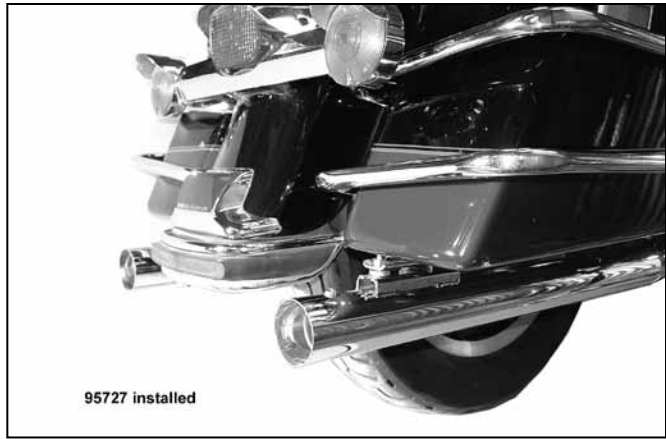

Samson Big Guns II- Touring

Features 1-3/4" head pipes with 2-3/4" full coverage heat-shields. All Big Guns II comes complete with mounting bracket and hardware.

95982 Fits Long Shots Slip-Ons

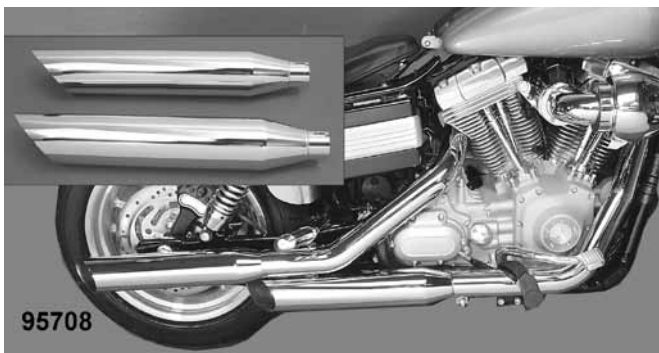

RMB Slip-On Muffler Sets

RMB styles include removable baffle set with one bolt for a quick 30 second removal. Install with stock header pipes. Mufflers a fit 1995-on FXD-FXDWG models.

PCP	Years
95708	1995-06
95709	2007-on
16283	Clamp set

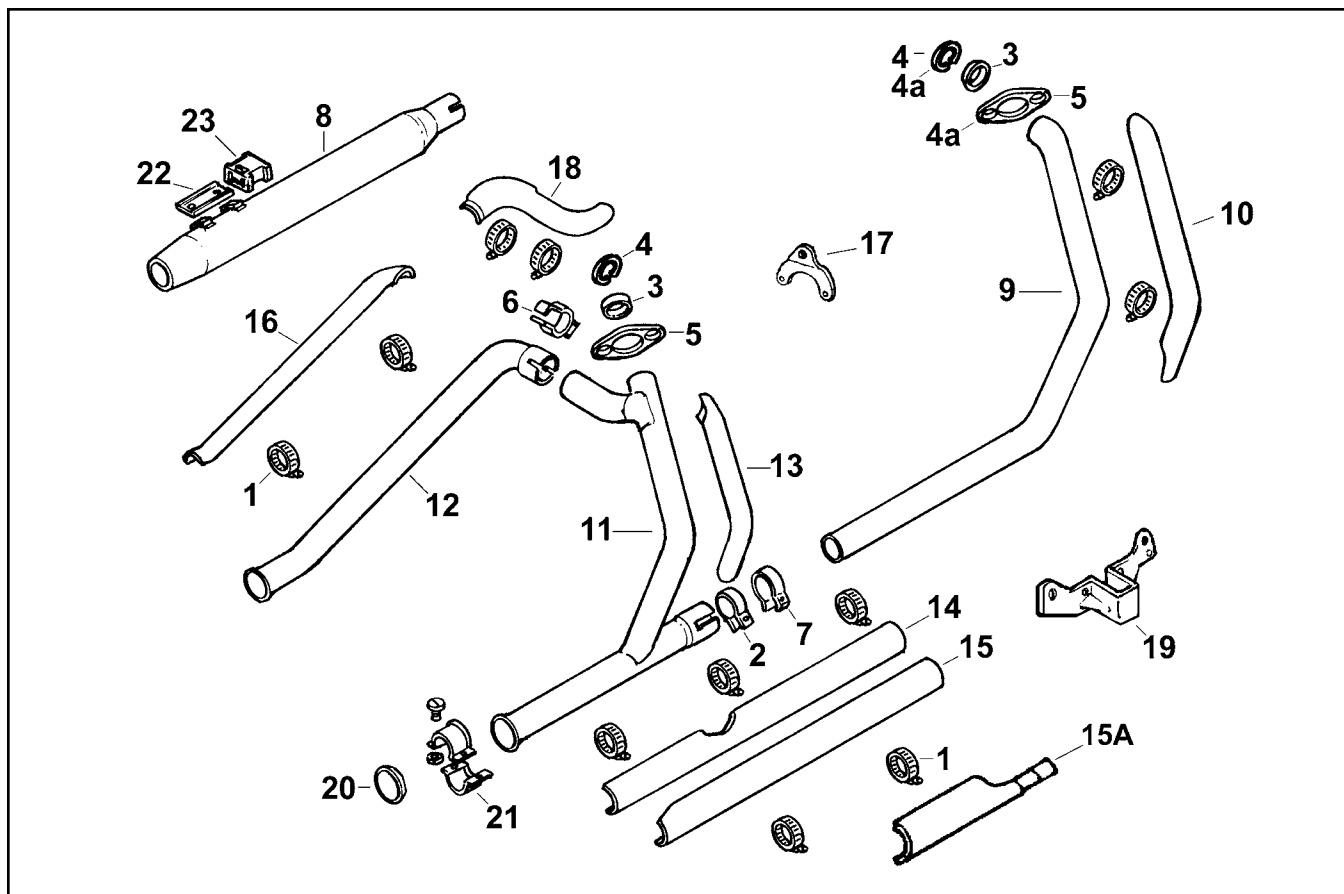

FLT Touring Dual Exhaust L1985-08 (USA)

Note specific year fitment

#	PCP	OEM	Description
1	16281	9955	Clamp, shield 1984-on (5 pk)
2	16282	65276-62	Muffler clamp 1984-94 (ea)
	16283	65296-95A	Muffler clamp 1995-on (ea)
3	79467	65324-83A	Gasket, exhaust port 84-on (10 pk)
4	11105	65325-83A	Snap ring, exh/gask. 84-on (10 pk)
4a	753		Exhaust flange kit (4 pcs)
5	16284	65328-83	Clamp, exh/manifold 1984-on (ea)
6	16285	65502-83A	Clamp, left exhaust pipe 84-88 ea
	16286	65502-89	Clamp, left exhaust pipe 89-94 ea
	16283	65283-94	Muffler clamp 1995-on (ea)
	16341	65620-98A	Clamp, exhaust all 2007-08
7	16287	65519-52C	Clamp, pipe to bracket 86-06 (ea)
	16342	65654-97	Clamp, exhaust pipe 2007-08
8	NA	65538-95	Muffler, left 1995-03
	NA	65539-95	Muffler, right 1995-03
9	95732	65621-83	Exhaust pipe, right front 1984-97
	95753	65621-99A	Exhaust pipe, right front 1999-06
	95759	65621-07	Exhaust pipe, right front 2007-08
10	45147	65630-83B	Shield, front exh/pipe 1984-08
11	95730	65626-85A	Exhaust pipe, right rear 1985-94
	95731	65626-95	Exhaust pipe, right rear 1995-97
	95754	65626-98C	Exhaust pipe, right rear 1998-06
	95760	65626-07B	Exhaust pipe, right rear 2007-08
12	95733	65627-85	Exhaust pipe, left L1985-94
	95762	65627-95A	Exhaust pipe, left 1995-98
	95755	65627-99A	Exhaust pipe, left 1999-06
	95761	65627-07	Exhaust pipe, left 2007-08

#	PCP	OEM	Description
13	45937	65632-83B	Shield, rear exh/pipe 1984-97
	45567	65951-98	Shield, rear exh/pipe 1998-08
14	94010	65634-81C	Shield, right exh/pipe 1981-91
15	45149	65634-92A	Shield, right exh/pipe 1992-97
	45568	65634-98A	Shield, right exh/pipe 1998-08
15A	45936	65611-92	Shield, right exhaust (rear) 92-94
	45211	65611-95	Shield, right exhaust (rear) 95-97
	45569	65952-98A	Shield, right exhaust (rear) 98-08
16	45216	65636-85	Shield, L/S rear exh/pipe 1985-94
	45158	65636-95	Shield, L/S rear exh/pipe 1995-98
	45570	65636-99	Shield, L/S rear exh/pipe 1999-06
17	16289	65645-89	Bracket, left rear exh/pipe 1989-94
18	45159	65647-83	Shield, left top exhaust pipe 83-98
	45571	65647-98	Shield, left top exhaust pipe 99-06
	45575	65636-07	Shield, left rear exh. pipe 2007-08
19	16290	65678-85D	Bracket, right rear exh/pipe 85-06
	16338	65619-98	Brkt tab, exh. mnt. at starter 07-08
	16343	65678-07	Bracket, rear exh. mount 2007-08
	16344	65988-07A	Brkt, exh. mnt. at starter 2007-08
20	79469	65721-85	Gask., muffler clamp L85-94 (10)
21	16233	65722-85	2-pc Muffler clamp L1985-94 (pr)
	16283	65296-95A	Muffler clamp 1995-08 (ea)
22	16291	65723-85	Mounting bracket L1985-on (ea)
23	23018	65724-85	Mount (rubber) L1985-on (pr)
-	14602	27714-06	Seal ring 2007-09 (10 pack)
-	29145	27719-07	Oxygen sensor 2007-09

Muffler Joint Gasket

Fits FLT 1985-94 and replaces

65721-85.

25226 5 pack



Mufflers



Cycle Shack 4" O.D. Touring Mufflers

Get a performance increase on FL, FLH, FLHR, FLHT Touring models from 1995-09 and will work with OE factory Y-pipe head pipes or Cycle Shack's Dresser Duallies (PHD-120, Preston #95860). Feature performance baffles and offer a deep throaty note that is mellow while cruising.

PCP Type for 1 3/4" head pipes

- 95721** Slash up (MHD 482 SU)
- 95722** SS (MHD 482 SS)
- 95723** Slash down (MHD 482 SD)
- 95724** Straight (MHD 482 ST)
- 95773** Oval (MOV-492)

Cycle Shack 4" O.D. Touring Mufflers

Get a performance increase on FL, FLH, FLHR, FLHX, FLHT Touring models from 1995-09 and will work with Cycle Shack's 2" head pipes (PHD-221, Preston #95863 and PHD-259, Preston #95862). Feature performance baffles and offer a deep throaty note that is mellow while cruising.

PCP Type for 2" head pipes

- 95798** SS (MHD 484SS)
- 95797** Slash down (MHD 484SD)
- 95799** Straight (MHD 484ST)

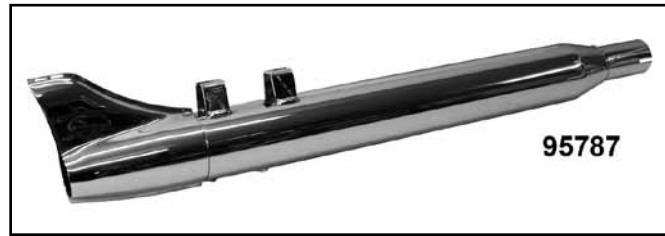

Cycle Shack 3"O.D. Touring Mufflers 1985-on

2 Piece endcap replacement mufflers are designed to fit the 1985-on FLT, FLHT, FLHT/C, FLHR Dresser models with Evo and Twin Cam motors. MHD-290 and MHD-291 Series feature an all steel performance baffle. MHD-289 and MHD-292 Series feature a woven stainless steel wool sound blanket around the baffle that cancels the sharp crackle in the exhaust note. The tone is till deep and throaty, but the baffle allows you to hear your stereo and works better with EFI TC-88 motors. Fits OE crossover "Y" pipe and bolts directly to OE saddlebag frame hangers. MHD-289/290 series mufflers are designed to fit 1985-94 models with OE flared end head pipes and OE coupler clamps. Sold in pairs. Clamps not included.

PCP Fits All Steel Performance Baffle

- 95776** 1985-94 SS (MHD-290SSA)
- 95778** 1985-94 Slash down (MHD-290SD)
- 95783** 1995-on SS (MHD-291SSA)
- 95785** 1995-on Slash down (MHD-291SD)

PCP Fits Woven Stainless Wool Baffle

- 95775** 1985-94 SS (MHD-289SSA)
- 95777** 1985-94 Slash down (MHD-289SD)
- 95784** 1995-on SS (MHD-292SSA)
- 95786** 1995-on Slash down (MHD-292SD)

Cycle Shack 3"O.D. Touring Mufflers 1985-on

2 Piece end cap mufflers. MHD-289 and MHD-292 Series feature a woven stainless steel wool sound blanket around the baffle that cancels the sharp crackle in the exhaust note. The tone is till deep and throaty, but the baffle allows you to hear your stereo and works better with EFI TC-88 motors. Fits OE crossover "Y" pipe and bolts directly to OE saddlebag frame hangers. MHD-289/290 series mufflers are designed to fit 1985-94 models with OE flared end head pipes and OE coupler clamps. Sold in pairs. Clamps not included.

PCP Fits All Steel Performance Baffle

- 95780** 1985-94 Rocket tip fishtail (MHD-290RA)
- 95782** 1985-94 Turn out/down (MHD-290TOA)
- 95787** 1995-on Rocket tip fishtail(MHD-291RA)
- 95789** 1995-on Turn out/down (MHD-291TOA)

PCP Fits Woven Stainless Wool Baffle

- 95779** 1985-94 Rocket tip fishtail (MHD-289RA)
- 95781** 1985-94 Turn out/down (MHD-289TOA)
- 95788** 1995-on Rocket tip fishtail(MHD-292RA)
- 95790** 1995-on Turn out/down (MHD-292TOA)



95860 Shown installed with Rocket Tip mufflers (sold separately)

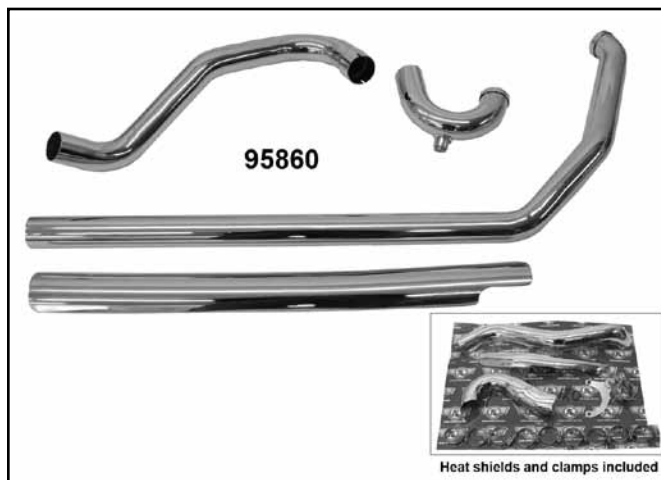

Heat shields and clamps included

Cycle Shack 1 3/4" Dresser Duallies with Slip-Fit Mufflers for Touring Models 1985-2008

These Dresser Duallies feature individual (PHD-120) head pipes with O₂ sensor bungs and eliminate the Y-pipe on the rear cylinder (OE crossover pipe) and are designed to fit 1985-on FLT, FLHT/C, FLHS and FLHR Road King models. **Order head pipes and mufflers separately.** Mufflers are available with SS (slash cut) and SD (slash down) style ends. These 3" O.D. touring mufflers attach to the OE saddlebag frame hangers. PHD-291 series features Cycle Shack's all steel performance baffle. PHD-292 series are a quieter muffler with less crackle due to their s/s wool sound blanket that lets you hear your stereo.

Duallies

95860 1985-08 PHD-120 Head pipes only (no flare end)

One Piece Mufflers

PCP All Steel Performance Baffle (Pairs)

95783 SS (MHD-291SSA)

95785 Slash down (MHD-291SD)

PCP Woven Stainless Wool Baffle

95784 SS (MHD-292SSA)

95786 Slash down (MHD-292SD)

Two Piece End Cap Mufflers

PCP All Steel Performance Baffle (Pairs)

95787 Rocket tip fishtail (MHD-291RA)

95789 Turn out/down (MHD-291TOA)

PCP Woven Stainless Wool Baffle

95788 Rocket tip fishtail (MHD-292RA)

95790 Turn out/down (MHD-292TOA)

Tech Note: #95860 When used with 1995-on mufflers will update the 1985-94 flared pipe style.



Cycle Shack FLT 2"OD Dresser Duals

Feature a stepped header pipe that exists on each side of the bike. Offers increased flow and performance for large displacement motors. Eliminates OEM rear cylinder Y-pipe. Fits 2007-on models. Order muffler separately.

PCP Description

95849 Header set

95775 "SS" style muffler

95776 Straight cut muffler

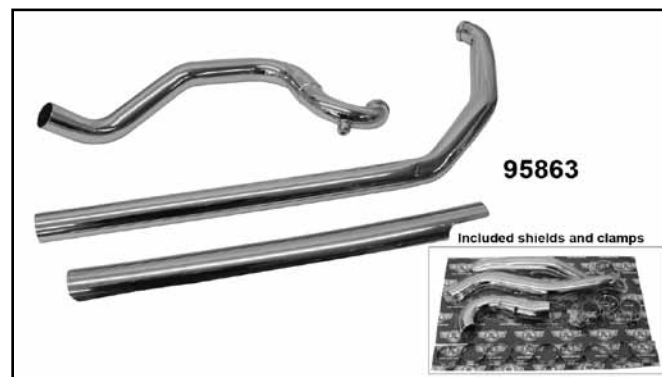

Included shields and clamps

Cycle Shack 2" O.D. Dresser Duallies for Touring Models 1995-08

These 2" O.D. Dresser Duallies stepped crossover head pipes offer increased flow and performance for large displacement motors (95c.i.+). They feature individual 2" O.D. stepped head pipes that exit on each side of the bike for a traditional Touring bike look and O₂ sensor bungs. They eliminate the OE rear cylinder Y-pipe. The MHD-320/MHD-324 series mufflers are matched with these 2" O.D. head pipes and feature a high-flow 2" O.D. baffle. The MHD-324 series mufflers feature a stainless steel sound blanket baffle so you can hear your stereo. Head pipes and mufflers sold separately.

PCP Type

95863 Head pipes (PHD-221)

PCP 2" Mufflers with Steel Baffle

95791 Slash down (MHD-320SD)

95793 SS (MHD-320SS)

95795 Straight (MHD-320ST)

PCP 2" Mufflers with Stainless Steel Blanket Baffle

95792 Slash down (MHD-324SD)

95794 SS (MHD-324SS)

95796 Straight (MHD-324ST)

True Dual Exhaust



Sold with chrome finish only. Black shown for reference only.

Cycle Shack 1 3/4" Dresser Duallies for Touring Models 2009-on

Tru dual, 2-into-1 separate headpipes replace the OE 2-1 header on 2009-on FLH, FLHR, FLT, FLHX models to help relieve excess heat under the riders right leg. They reuse the OE factory heatshields. Full 1 3/4" O.D. headpipes including the crossover pipe on the front cylinder for improved flow and performance.

95861 (PHD-159)

Cycle Shack 2" Dresser Duallies for Touring Models 2009-on

Tru dual, 2-into-1 separate head pipes replace the OE 2-1 header on 2009-on FLH, FLHR, FLT, FLHX models to help relieve excess heat under the riders right leg. Full 2" O.D. stepped head pipes provide increased flow and performance on mototrs over 100 c.i. Reuses OE heat shields on head pipes and is supplied with lower heat shield and left side crossover heat shield. Should be used with MHD-484, MHD-320 or MHD-324 series Cycle Shack mufflers with 2" O.D. baffles.

95862 (PHD-259)

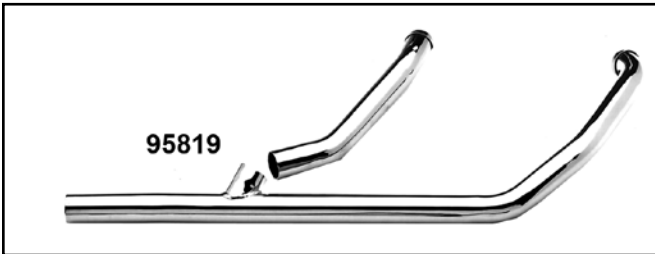

95819

Paughco 1-3/4" 2007 Touring Exhaust Systems

Head pipe sets fit 2007 FLT, FLHT and Road King models. Heat shields are recommended.

PCP Item

- 95819** 2-into-1 head pipes only
- 95820** Independent dual head pipes only with a crossover bracket
- 95821** Crossover dual head pipes only with a crossover bracket

Heat Shields

- 94052** Front heat shield
- 94029** Low front shield with notch for #95819 and #95821
- 94053** Low front shield without notch for #95820
- 94054** Rear shield for #95819
- 94055** Rear shield for #95821
- 94056** Crossover shield for #95820, #95821
- 94057** Snail shield for right side rear cylinder on #95820

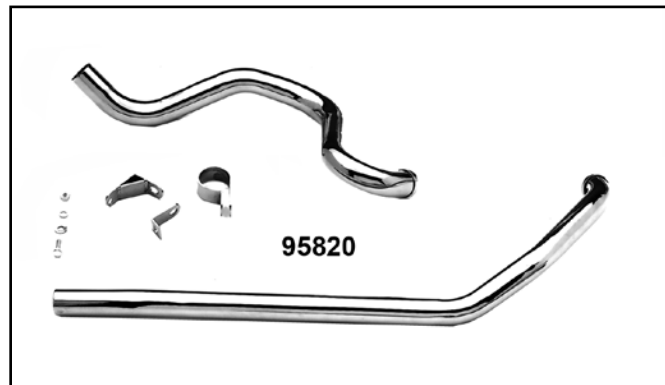

95820

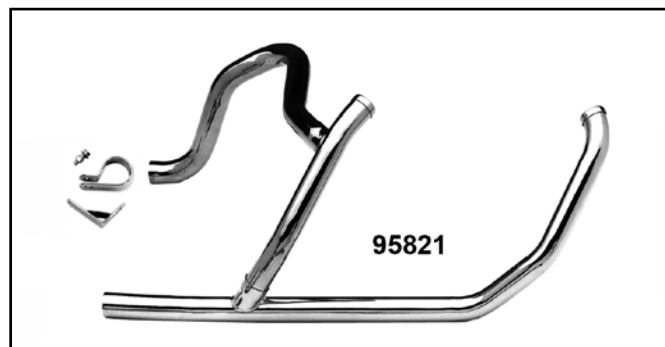

95821

Oxygen Sensor Plug

Fits exhaust fitting on 2006-on FXD, 2007-on FLT and FXST models.

PCP Item

- 73734** Plug (each)
- 29145** Sensor (pair)



73734



29145

Paughco 1995-06

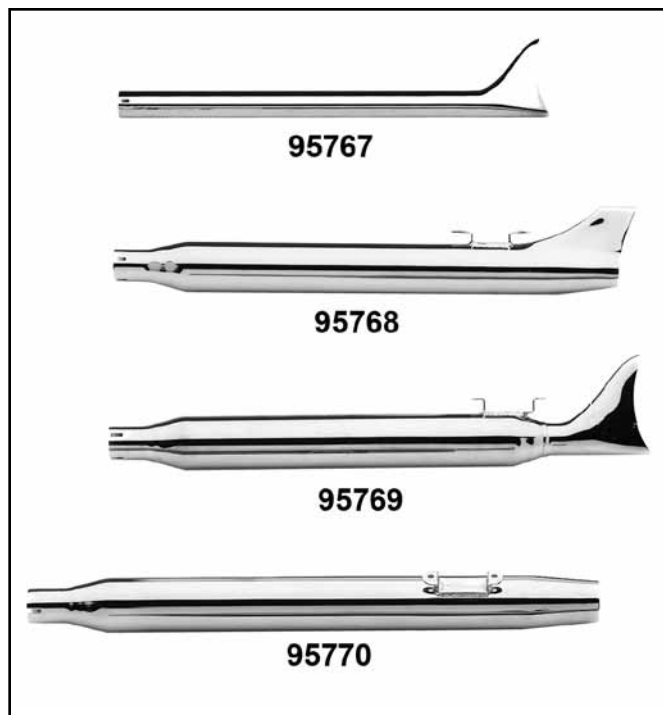

Paughco Touring Mufflers 1995-07

Extensions and mufflers are intended for use on 1995-07 Touring models. All measurements listed are overall length. Sold each.

1-7/8" Diameter Straight Fishtails

PCP	Length	Type
95767	31"	Fishtail
16346		Hanger clamp



3" Diameter Mufflers

Require no additional brackets for installation.

PCP	Length	Type
95768	31"	Rocket
95769	31"	Fishtail
95770	30"	Tapered

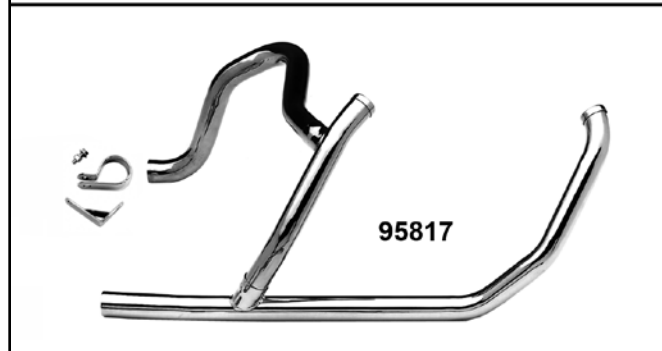
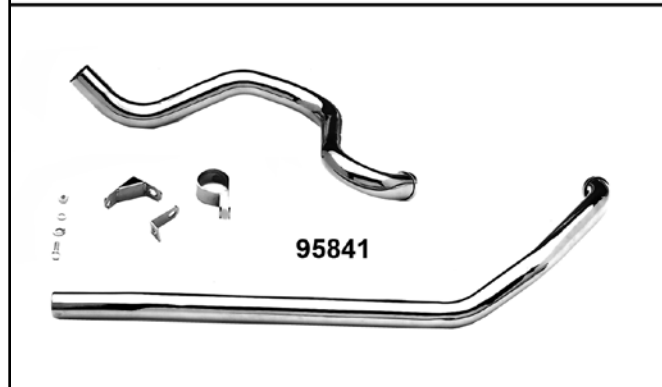
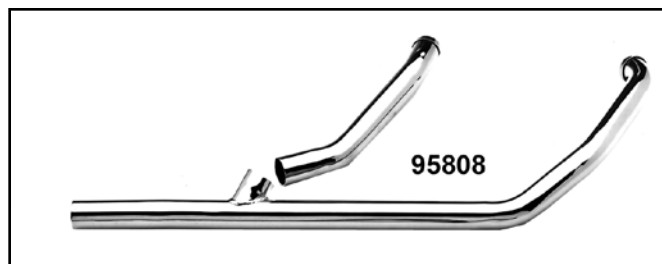

Paughco 1-3/4" Touring Exhaust 1995-2006

Head pipe sets fit 1995-2006 FLT, FLHT, FLHS and Road King models. Heat shields are recommended.

PCP	Item
95808	2-into-1 head pipes only
95841	1995-98 Independent dual head pipes only with a crossover bracket
95856	1999-06 Independent dual head pipes only with a crossover bracket
95817	Crossover dual head pipes only with crossover bracket

Heat Shields

94052	Front heat shield
94029	Low front shield with notch for #95808 and #95817
94053	Low front shield without notch for #95841 and #95856
94054	Rear shield for #95808
94055	Rear shield for #95817
94056	Crossover shield for #95841, #95856 and #95817
94057	Snail shield for right side rear cylinder on #95841 and #95856

Paughco 1985-94

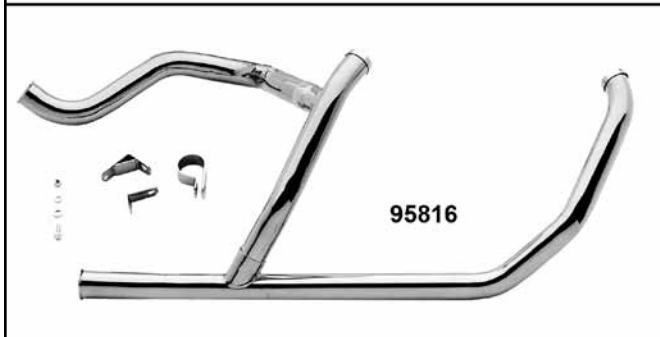
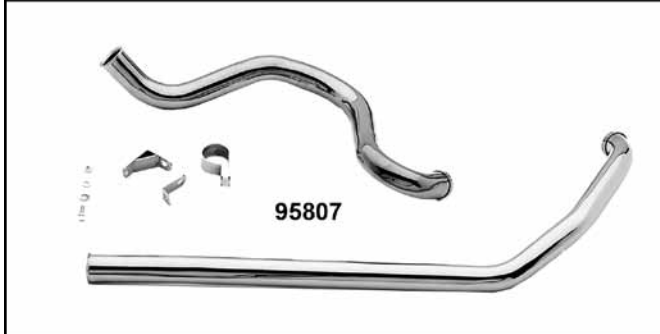
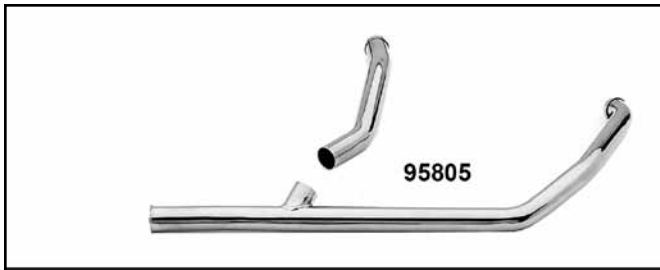

Paughco 1-3/4" Touring Exhaust L1985-94

Head pipe sets will fit all L1985-94 Evolution FLT, FLHT and FLHS and Road King models. Heat shields are highly recommended.

- | PCP | Item |
|-------|---|
| 95805 | 2-into-1 headpipes only |
| 95807 | Independent dual headpipes with crossover bracket |
| 95816 | Crossover dual headpipes with crossover bracket |

Heat Shields

- | | |
|-------|---|
| 94052 | Front heat shield |
| 94054 | Rear shield for #95805 |
| 94055 | Rear shield for #95816 |
| 94056 | Crossover shield for #95807 and #95816 |
| 94057 | Snail shield for right side rear cylinder on #95807 |



Paughco Rocket Mufflers Touring L1985-94

No additional brackets required for installation. 3" Diameter rocket muffler measures 31" long.

- | | |
|-------|--------------------------|
| 95763 | Rocket muffler (each) |
| 16345 | V-clamp for late 1985-94 |

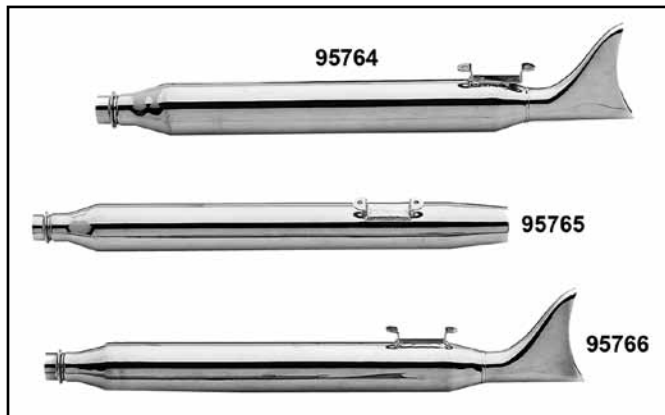

Paughco Touring Mufflers 1985-94

3" Diameter mufflers are intended for use on late 1985-94 Touring models and bolt right on with no additional brackets required. All measurements listed are overall length. Sold each.

- | PCP | Length | Type |
|-------|--------|----------|
| 95764 | 29" | Fishtail |
| 95765 | 29" | Tapered |
| 95766 | 31" | Fishtail |
| 16345 | | V-Clamp |



True Dual Exhaust Stock Type 2 Into 1



True Dual Chrome Exhaust Systems-Paughco

These systems feature a single pipe for each side. Each pipe is independent, rear pipe for the left and front pipe for the right without intersection. 1-3/4" O.D. Order 2 piece heat shield set separately.

PCP	Application	Heat Shield
95841	1985-98 FLT	94044
95856	1999-06 FLT	94044
95842	1986-94 FXST-FLST	94045
95843	1995-99 FXST-FLST	94045
95844	2000-06 FXST-FLST	



95802

Stock Type 2 into 1 - Chrome Pipes

1984 Evolution type fits FXST 1985-99 and FLST 1986-99 when early FL look is desired.

95802	1984-99 FXST-FLST
45562	Chrome rear heat shield for #95802
95803	1984-94 FXR-FXRS
95805	1985-94 Evo FLT



95842 left side view

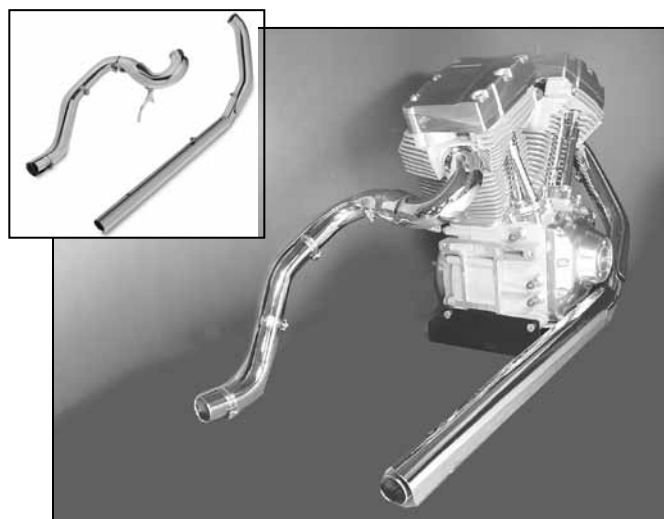

VT True Dual Cross Over Header

Fits FLT, FLHT, FLHR, FLTR. Heat shields, clamps, and hardware are included. Order 1995-06 type muffler separately.

PCP	Item
95852	1995-06 Header pipes
95857	2007-08 Header pipes



Radii True Dual Kit for Touring Models

Includes chrome true dual crossover kit with clamps and wide oval muffler set.

PCP	Item
95858	1995-06
95859	2007-08

Dual Exhaust



Chrome Dual Pipe Cross Over Systems-EVO

Part Number	Model Years	Heat Shield
95814	FXST-FLST 1987-99	94037
95818	FXST-FLST 2000-06	
95816	FLT 1985-94	94039
95817	FLT 1995-06	94040

Chrome Dual Crossover Headers by Run Road-er for 1995-99 FXST-FLST

1-3/4" Pipes come with 2 chrome heat shields, 2 aircraft style clamps for pipe junctions, 2 heavy duty muffler mounting brackets and a replacement, chrome shifter linkage rod. Uses stock exhaust port rings and retainers and can install any 1-3/4" muffler pipe on the system. **Note:** Installation of left side muffler mounting bracket requires drilling and tapping of lower frame boss.

95814 1995-99

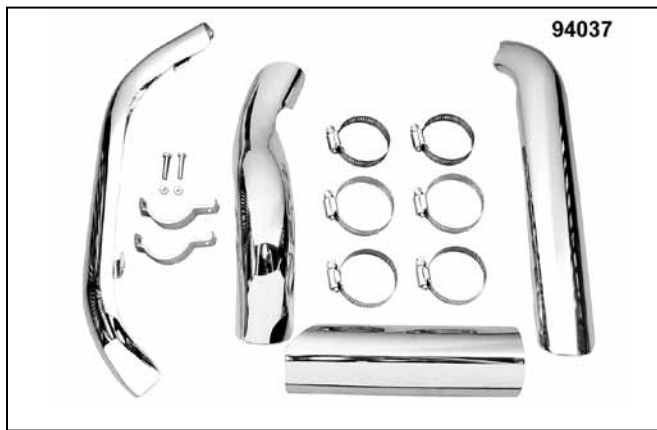

FLT Extended Front Exhaust Heat Shield

Covers the exposed exhaust pipe adjacent to rider footboard. Mounts with existing hardware. 65694-05A.

59702 1983-99 FLT models
82108 2000-on T/L

Chrome Universal Heat Shields

Stylish shield feature a groove or flame design.

Groove	Flame	Size
59695	59698	4"
59696	59699	6"

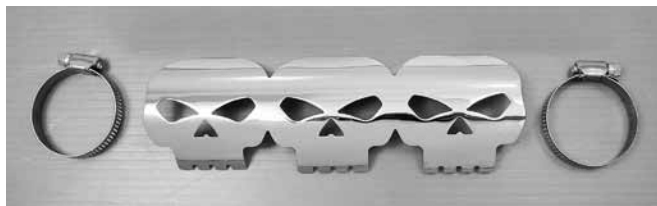

Chrome Skulls Heat Shield

45162 9" Long

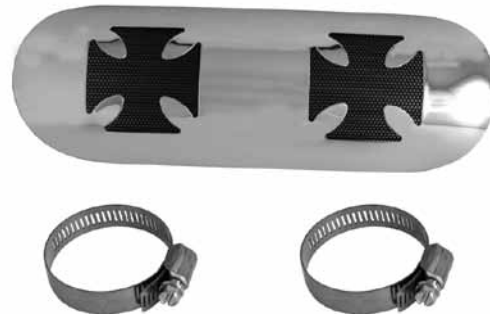

Maltese Chrome Heat Shield

45157 9" Long

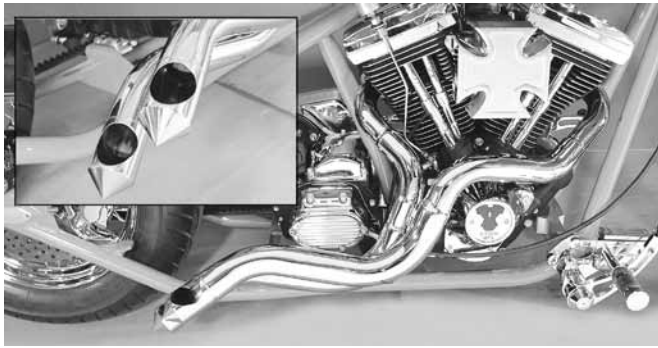

2-1/4" Chrome Exhaust Cone Cover Ends

Fits 2-1/4" straight pipes with straight cut ends. Cones can be rotated to desired position, then drilled for installation.

59715

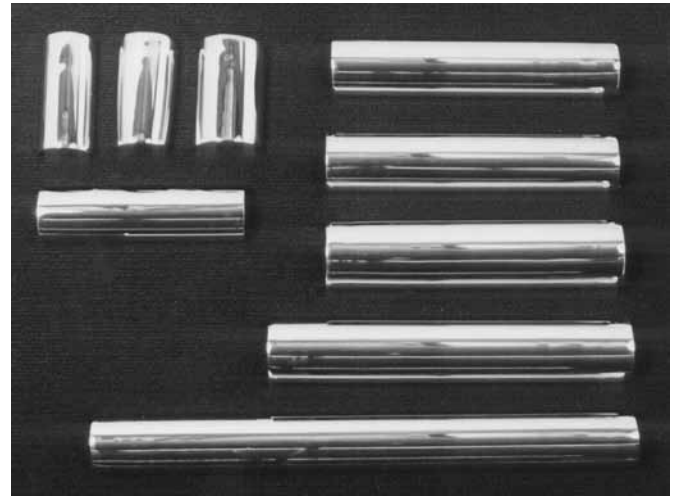

Chrome Universal Straight Heat Shields

Heat shields include mounting clamps and are available for 1 3/4" or 2 1/4" pipes. Sold each.

For 2 1/4" Pipes

- 45206** 4" heat shield
- 45209** 10" heat shield

For 1 3/4" Pipes

- 94012** 10" heat shield
- 94013** 12" heat shield
- 94014** 18" heat shield



Six Gun Pipe End Set

Tips fit pipes with 2-1/4" full coverage heat shields over 1-3/4" pipes.

59877



2 Stage Torque Baffle Set

4 Piece set allows variation of air flow for 2-1/4" pipes. **59597**



Chrome Billet Aluminum Custom End Caps

Fits all 2.25" pipes. **73562**



Billet Pipe Ends for 2.25" Straight Pipes

- | | |
|--------------|----------------|
| PCP | Finish |
| 21681 | Black anodized |
| 21682 | Chrome |

Heat Shields

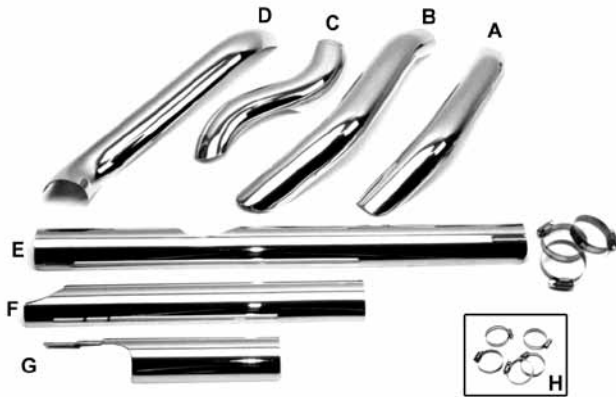

Chrome FLT Stock Heat Shields for 1983-on

PCP	Application
45147	(A) 1983-on Front head pipe (65630-83C)
45148	(B) 1984-97 Rear head pipe (65632-83C)
45159	(C) 1983-on Left top (65647-83)
45216	(D) 1985-94 Left rear (65636-85)
94010	(E) 1981-91 Lower (22 1/2") (65634-81C)
45149	(F) 1992-on Low right (65634-92)
45936	(G) 1992-94 Low right rear (65611-92)
16281	(H) 1984-99 Clamp, (shield) (9955) (5pk)



Evo FXST Muffler/Drag Pipe Heat Shields

Designed to fit with either Drag or Muffler type pipes. Covers do not have cut out for cross-over tube. Sold in sets.

94020	Smooth
94021	Perforated
94024	Ribbed
94025	Smooth XL 1986-03



Chrome Heat Shields

3171	Front FLT 1981-91
94004	FXR equalizer 1983-on, FXST 1986-99



Sportster Exhaust Pipe Heat Shields 1986-03

Chrome covers for Stock or Drag pipes.

94025	Set	Drag/Custom pipes
94027	Set	Cycle Shack drag/muffler
94025	Set	Drag pipes
45160	Front	Cycle Shack shot gun pipe 1990-99
45161	Rear	Cycle Shack shot gun pipe 1990-99

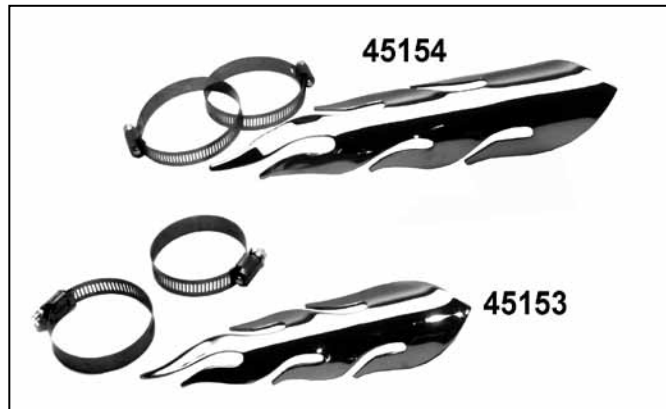
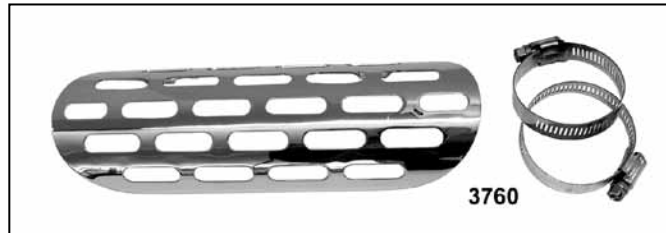

Universal Heat Shields

Fits 1-1/2" to 2-5/16" Pipes and includes clamps for installation. Sold each.

PCP	Length	Type
3760	9"	Perforated
45153	8"	Flame
45244	9"	Flame
45154	11"	Flame

Heat Shields



BT Exhaust Gasket Set BT 1985-on

Includes 2 snap rings.
25607

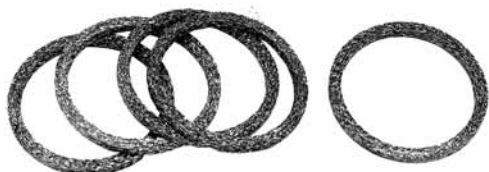

Mesh Exhaust Port Gasket 1999-on

25608 5 Pack



Chrome 2:1 Shield Set

Fits PCP #95802 1984-99 FXST-FLST exhaust.
45562



Chrome Front Muffler Pipe Junction Shield

PCP	Application
45556	1984-on FX , XL 1986-03
45558	1986-on FLSTF (65432-89)

Chrome Heat Shields

Stock replacement shields include worm clamps.
45564 1986-99 FXR-FXST (65410-83)



Chrome Rear Heat Shield

Shield is contoured to fit 1990-94 FLSTF with stock exhaust.
82087 65464-89



Chrome Stock Heat Shields 1986-on

PCP	Application
45565	Front FXST-FXR 1986-95 (65732-86)
45566	Rear FXST-FXR 1986-99 (65702-86)



XL Heat Shields 1986-03

94025 Set for staggered duals



Heat Shield

Fits the lower part of the front pipe on FL crossover dual or 2-into-1 exhaust systems for Softail® models.

94011	10" Long with notch
1164	7" long

Exhaust Hardware



Exhaust Port Fasteners

The bolt holds the pipe secure, not merely by thread tension, but clamps the pipe to the head by wedging the patterned washers against the pipe while the washers are, in turn, wedged between the pipe and the "E" clip locks fitted to the bolt heads.

2017 Evolution Big Twin motors 1984-99



Evo Exhaust Flange Kit

Each kit includes: 2 chrome exhaust flanges, retaining rings, exhaust gaskets and chrome acorn nuts and washers.

27202 BT 1984-on, XL 1986-03



Genuine James Exhaust Gaskets.

PCP	Description
79467	Pipe to head 1984-91 BT & XL Evo (65324-83) (10)
79468	Pipe to head 1992-on BT & XL (65324-83-A) (5)
79469	Muffler clamp 1985-on all FLT (65721-85) (10 pk)
79470	Inter connect 1982-on 883,1100 (65781-82) (ea)
79472	Inter connect 1991-on Dyna (65826-90) (ea)



Stainless Steel Taper Valve Kit

Includes 2 stainless steel extruded sleeves to fit between pipe and exhaust port. Aids in back pressure when range O.D. or drag pipes are used. Kit includes solid copper machined exhaust seals which will not restrict gas flow.

59370



James Evo Exhaust Nut Kit

Includes 4 chrome acorn nuts, 4 washers, and 2 mesh gaskets, for 1984-03 883-1100-1200 & 1340 models.

79833



Colony Exhaust Stud and Nut Kit

Fits Evo, Twin Cam models.

72188

EVO Exhaust Port Gasket

Stainless outer body and "Crush" fibre inner body

25225 Sold in 10 packs.



Exhaust Stud Kit

Includes 4 studs and 4 stainless flanged nuts. Fits XL 1986-03 and BT 1984-96.

24071

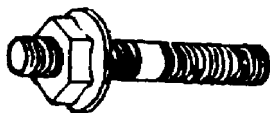

Jims Exhaust Stud Drill Fixture

Fits BT and XL 1984-on exhaust ports to align for the drilling of a broken exhaust stud.

31524

